

Goods covered under 5 year limited warranty offered by Euro-Rite Cabinets Ltd. For full warranty information, please visit www.eurorite.com -support-warranty.

Les marchandises couvertes au-dessous de 5 ans ont limité la garantie offerte par Euro-Rite Cabinets Ltd. Pour des informations complètes de garantie, visitez svp www.eurorite.com - appui - garantie

Las mercancías cubiertas bajo 5 años limitaron la garantía ofrecida por Euro-Rite Cabinets Ltd. Para la información completa de la garantía, visite por favor www.eurorite.com - ayuda - garantía

Assembly Instructions

Instructions D'Assemblée
Instrucciones de asamblea

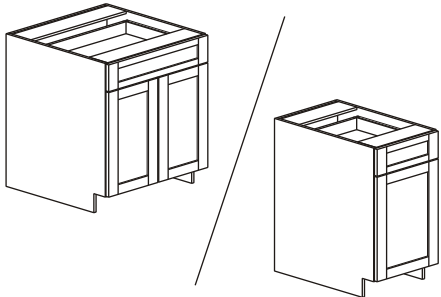



Base Cabinet with 1 Soft Close Drawer

Cabinet bas - avec 1 tiroir
Gabinete bajo - con 1 cajón











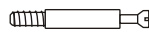







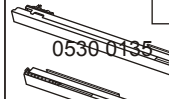

1

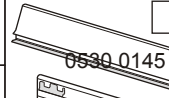
 x 10
  x 10

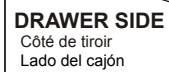

2

BOX Boîte Caja A	□ 10  0540 0005	□ 10  0540 0025	□ 10  0540 0015
	□ 2  0540 0055	□ 2  0540 0095	□ 4  0550 0005
	□ 2  0550 0015	□ 12  0540 0090	□ 1pr  0530 0135  0530 0140
□ 1  0550 0025	□ 1 pr  0530 0160  0530 0165	□ 1pr  0530 0145  0530 0150	
□ 2  0530 0155	□ 1 pr  0530 0170  0530 0175	□ 1pr  0530 0145  0530 0150	

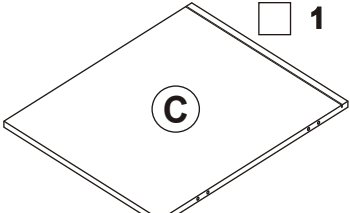
 □ 1
ASSEMBLY SHELF
Étagère d'Assemblée
Estante de la asamblea

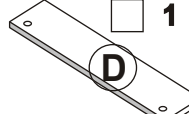
 □ 1
FRONT RAIL
Rail avant
Carril delantero

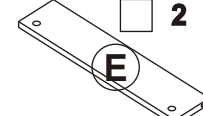
 □ 2
BACK RAIL
Rail arrière
Carril trasero

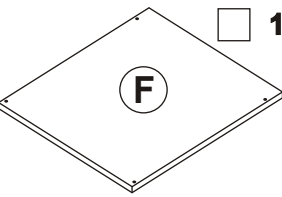
 □ 1
DRAWER BOTTOM
Le fond de tiroir
Fondo del cajón

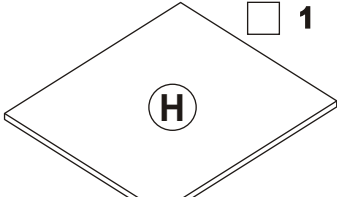
 □ 1
ADJUSTABLE SHELF
Étagère réglable
Estante ajustable

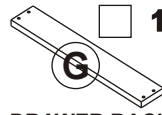
 □ 1
DRAWER BACK
Dos de tiroir
Parte posteriora del cajón

BOX
Boîte
Caja

B

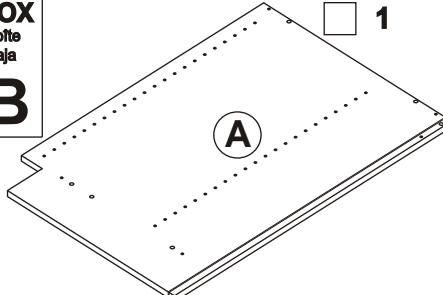
 □ 1
LEFT HAND GABLE (SIDE PANEL)
Pignon de main gauche (panneau latéral)
Aguilón de la mano izquierda (panel lateral)

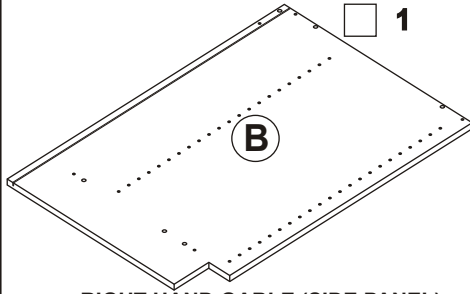
 □ 1
RIGHT HAND GABLE (SIDE PANEL)
Pignon droit (panneau latéral)
Aguilón derecho (panel lateral)

BOX
Boîte
Caja

C

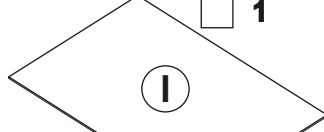
 □ 1
BACKBOARD
Panneau arrière
Tablero trasero

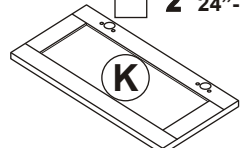
 □ 1 9"-21" w
□ 2 24"-36" w
DOOR PANEL
Panneau de porte
Panel de la puerta

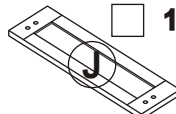
 □ 1
DRAWER FACE 6" h
Visage de tiroir
Cara del cajón

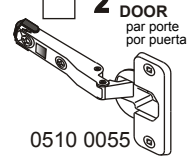
 □ 2 PER DOOR par porte por puerta
0510 0055

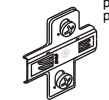
 □ 2 PER DOOR par porte por puerta
0510 0100

 □ 1 PER DOOR par porte por puerta
0550 0025

3

x 4

X 2
PER DOOR
par porte
por puerta

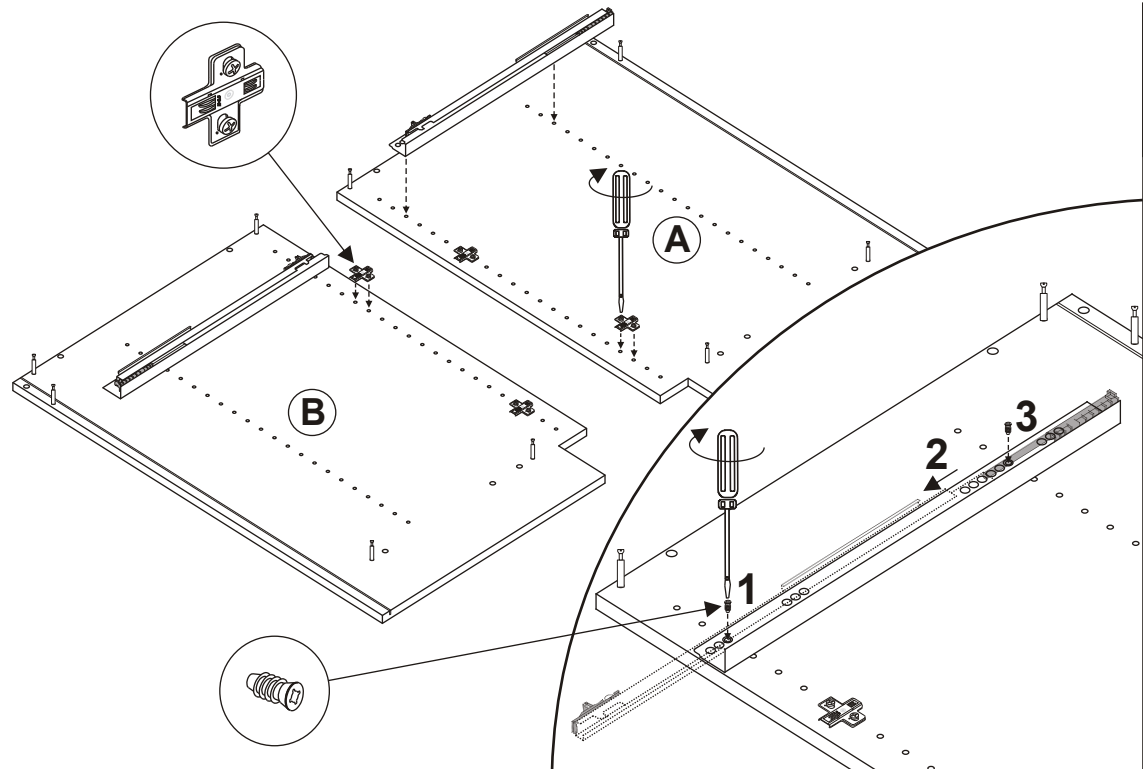

4

C → A
 D → A
 E1 → A
 E2 → A

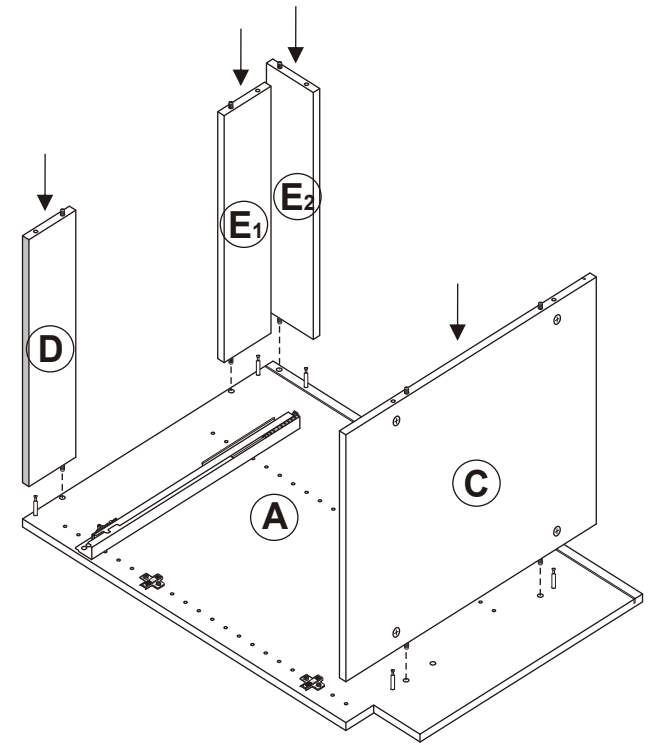

5

B → C,D,
E1&2

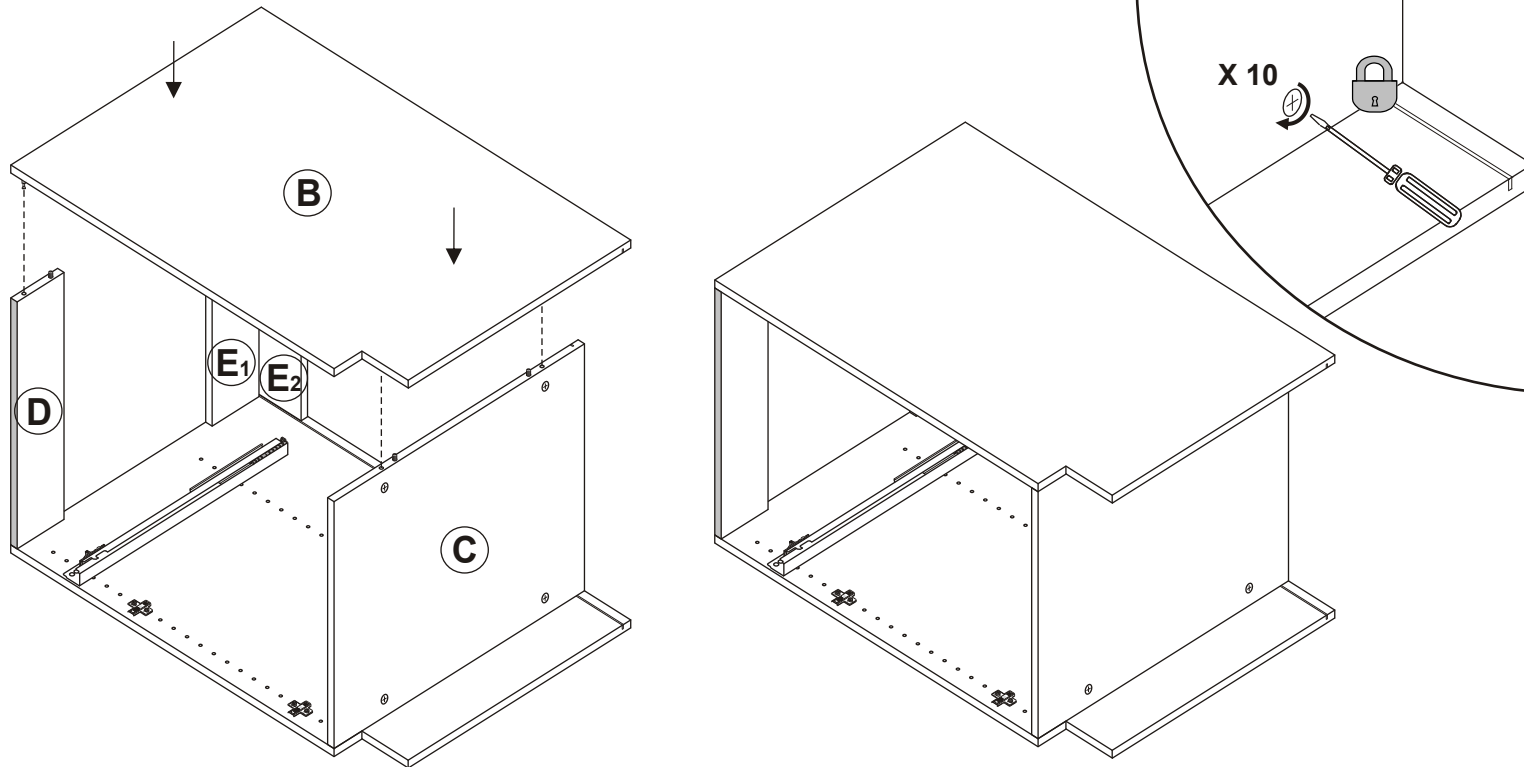

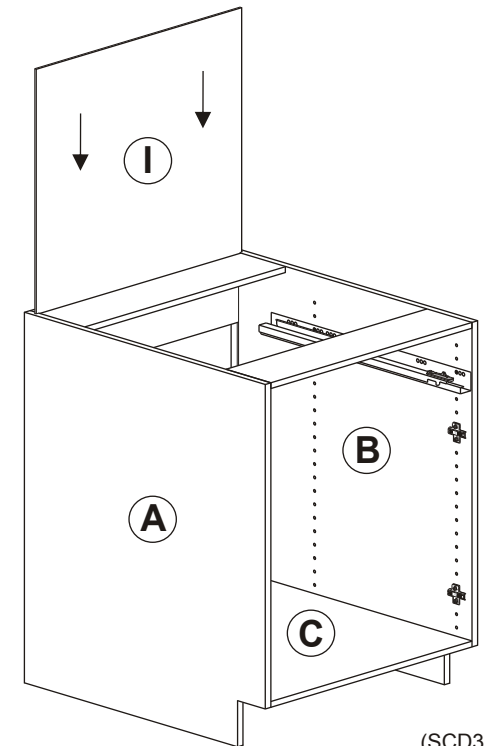

6

I → A,B
&C



7

 x 2

 x 2

I  E2

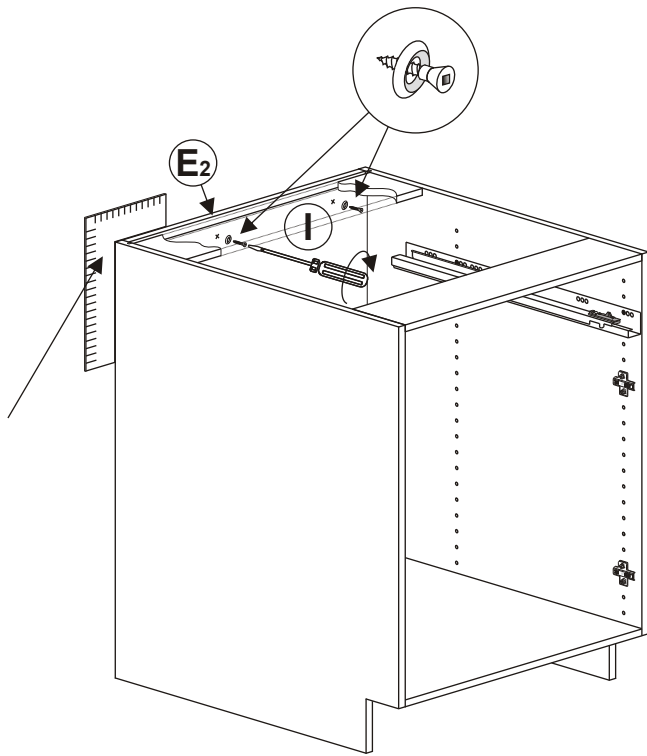

8

 x 4

 x 2

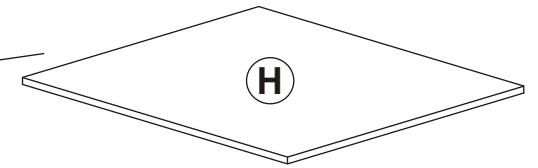
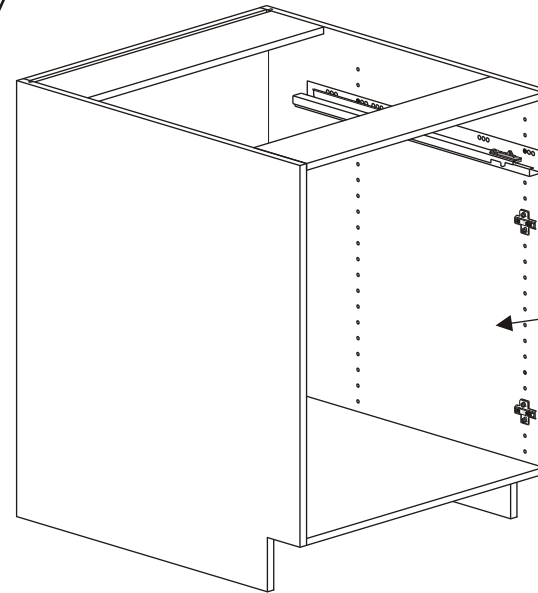
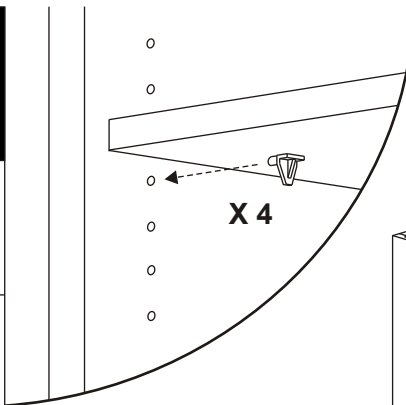

X 2

9

 x 4

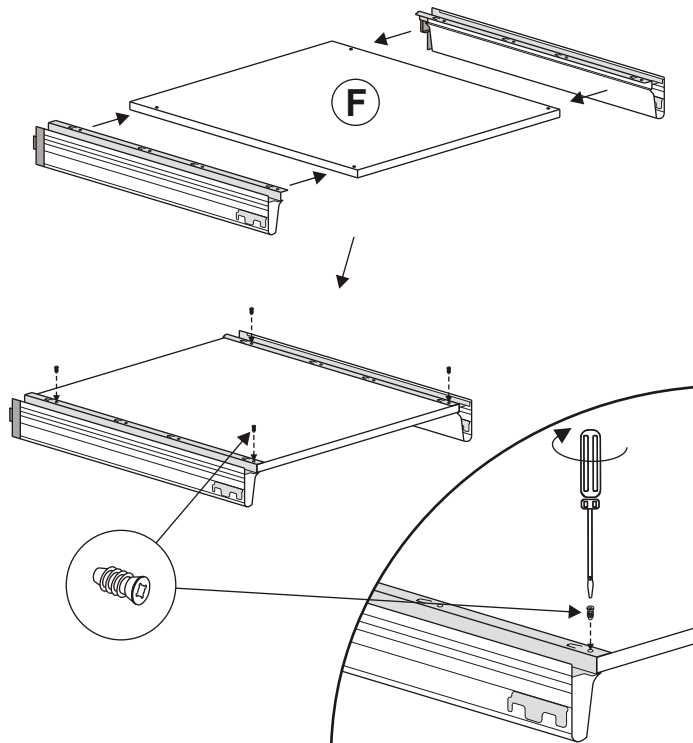

10

 x 1

 x 1

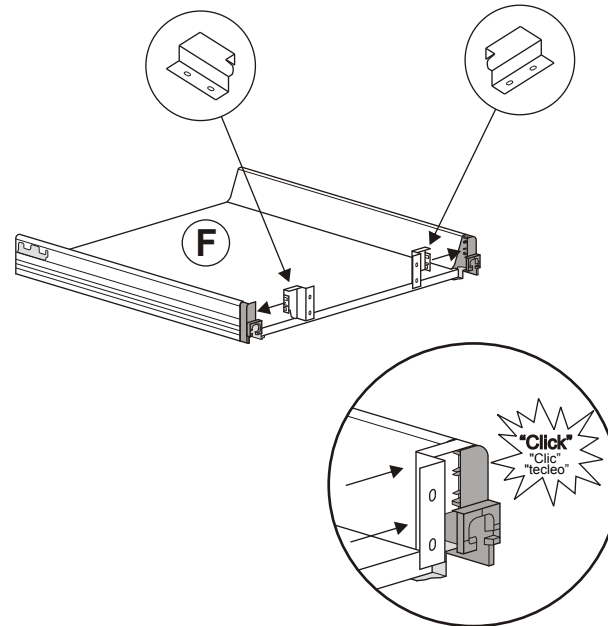

11

 x 4

G → F

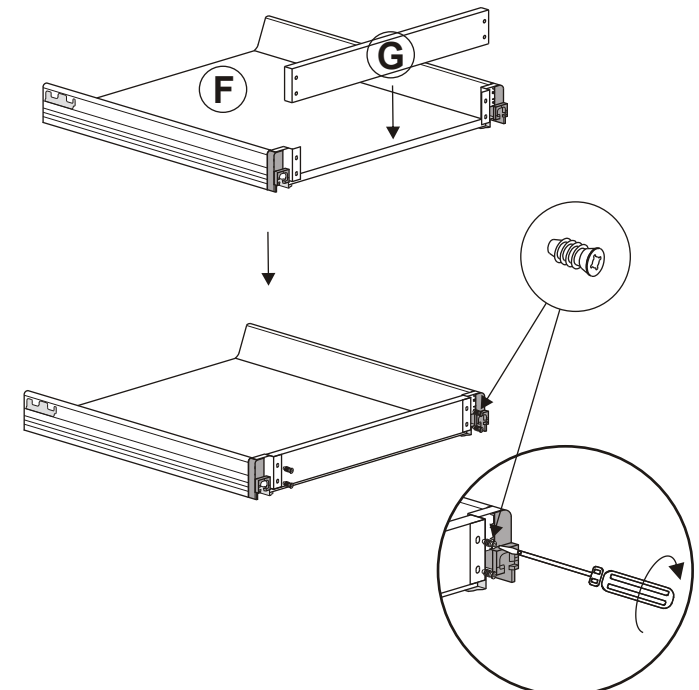

12

x 2

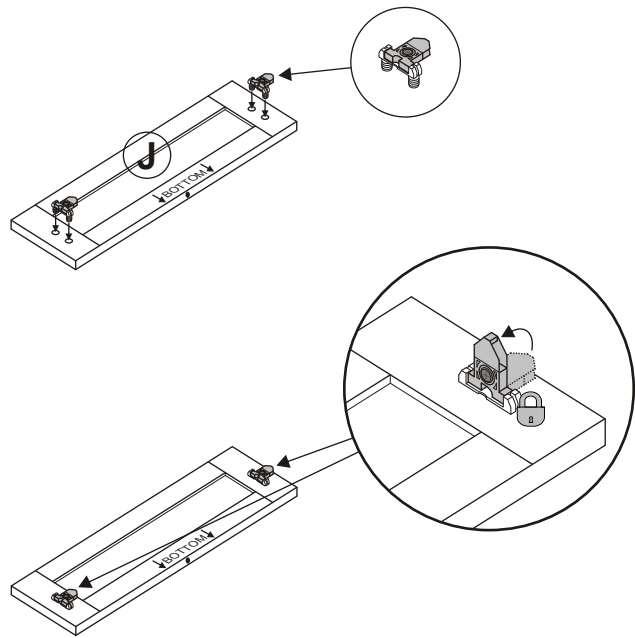

13

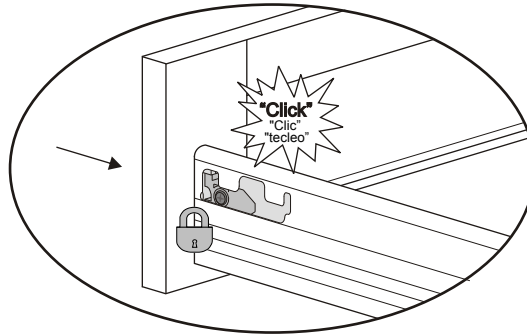
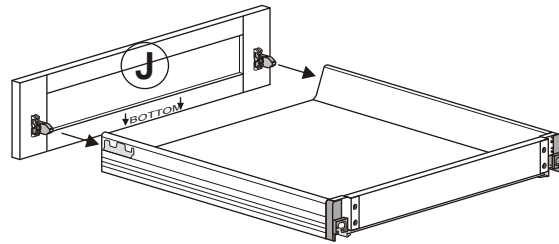

14

x 2
PER DOOR
per porte

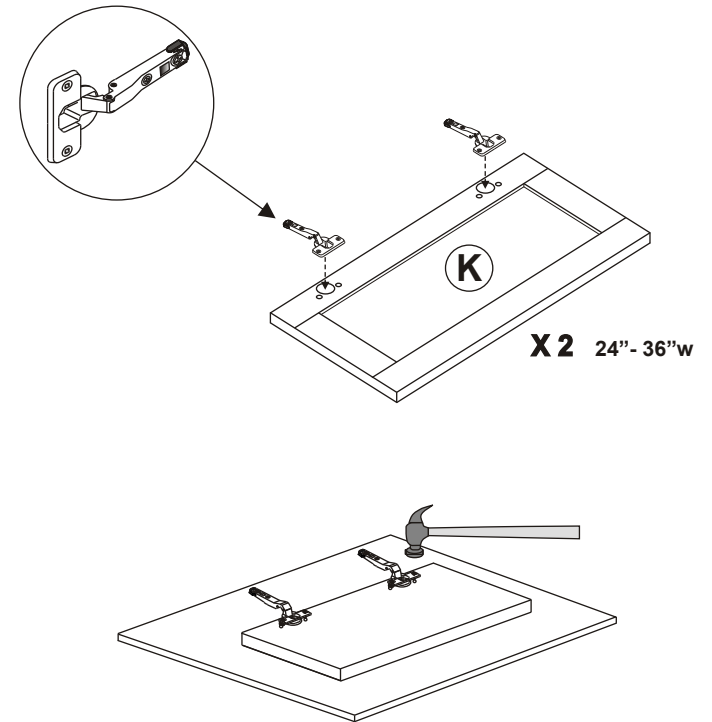

X 2 24"-36" w

15

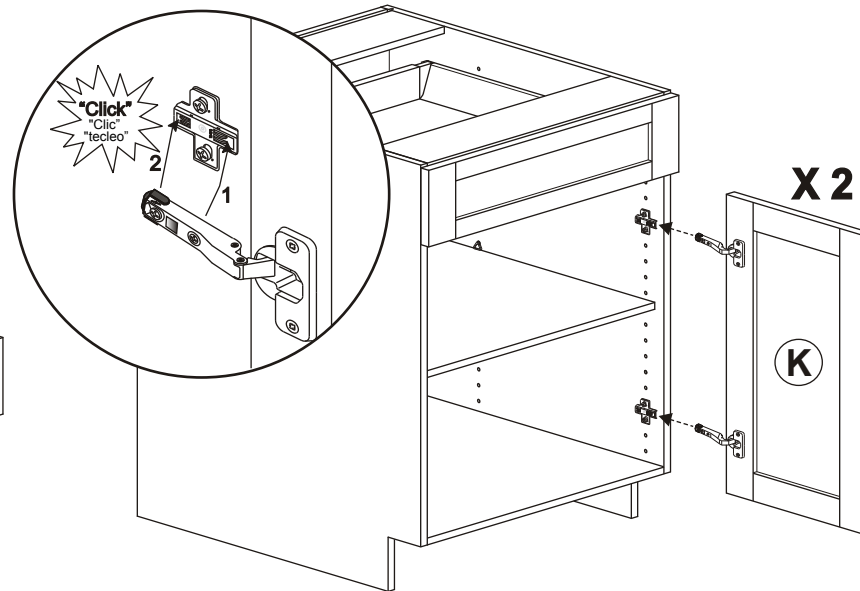
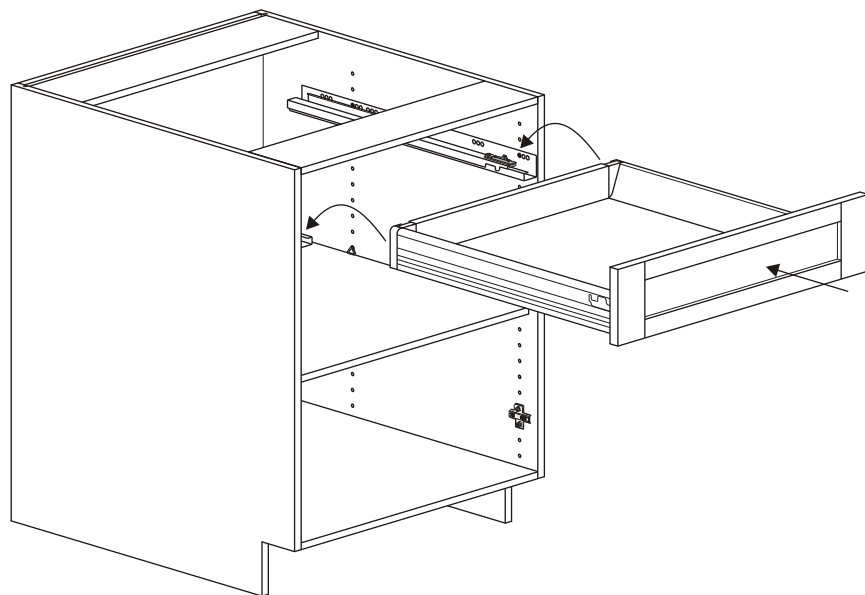

X 2 24"-36" w

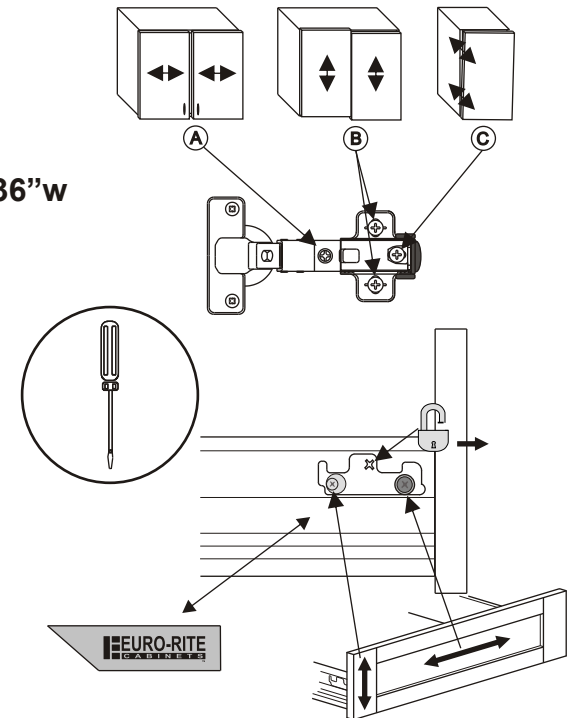

EURO-RITE
CABINETES